

**HIGH POTENTIAL
DIELECTRIC STRENGTH TESTING
with
HYPOT JUNIORS
AUTOMATIC SQUAWKER HYPOTS
and
AC/DC and DC HYPOT JUNIORS**



8221 North Kimball Avenue
Skokie, Illinois 60076

INSTRUMENTS FOR MEASURING

- Insulation resistance . . . the VIBROTEST®
- Ground resistance . . . the VIBROGROUND®
- Earth resistivity . . . the VIBROGROUND®
- High voltage breakdown, AC-DC . . . the HYPOT®

1911

TABLE OF CONTENTS

Preface.	4
Introduction	5
The Dielectric Test.	5
Method of Application.	6
Hypot Junior Design Features	7
Output Voltage vs. Current	9
Testing Capabilities	10
Leakage Light Adjustment	12
The Breakdown Light.	13
Automatic Squawker Hypots.	14
Design Features.	14
AC/DC and DC Hypot Juniors	16

PREFACE

This manual describes the Associated Research line of collapsing field type of high voltage test sets, known as Hypot Juniors. The instruments can be used for production testing of components, assemblies, small equipment, and consumer type appliances. Included are the standard AC Hypot Junior, AC Automatic Squawker Hypot, AC/DC Hypot Junior, and the DC Hypot Junior.

The first section gives general theory and application of the instruments' use in AC testing, gives circuit details, and explains the function of the various components of the instrument with particular emphasis on the AC models. The theory of operation, methods of connection to the item under test, and methods of performing the test are also explained. The last section points out the main differences between the AC models and the DC units, and the application to DC testing.

HIGH POTENTIAL DIELECTRIC STRENGTH TESTING

INTRODUCTION

The HYPOT JUNIOR was introduced in 1948 in answer to a growing need for a portable, inexpensive, yet accurate instrument for applying high voltage tests to a wide variety of electrical equipment and components. The HYPOT JUNIOR is properly referred to as a HIGH POTENTIAL DIELECTRIC STRENGTH testing instrument, although instruments of this general type are loosely referred to as "breakdown" testers, "hi-pots", etc.

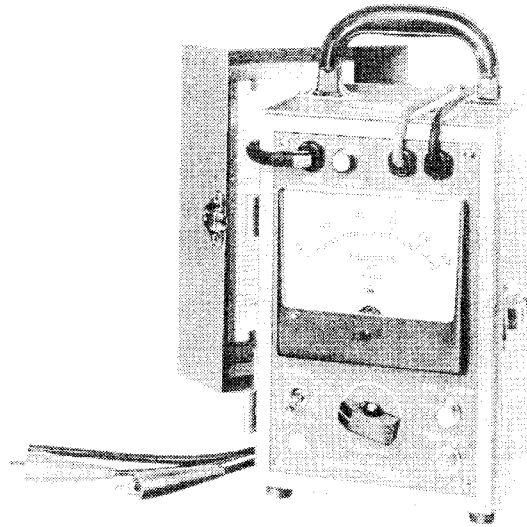

Incorporated in these instruments are several advanced design features not previously found in this class. These features will be explained in detail later.

HYPOT JUNIOR
SIMPLIFIED SCHEMATIC

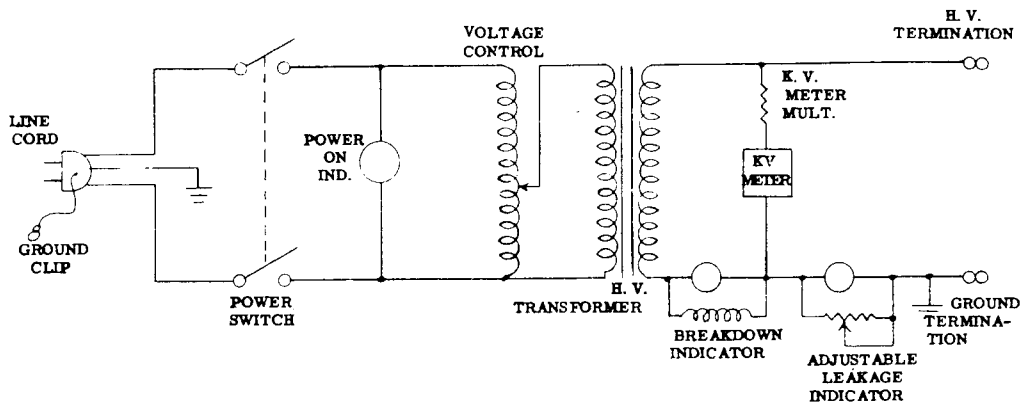

THE DIELECTRIC TEST

Since a HYPOT JUNIOR is an instrument for making dielectric strength tests, we can get an excellent idea of the field of application by considering the PURPOSES and TYPES of high potential dielectric tests. Basically, a high potential dielectric test is the deliberate application of a predetermined over-voltage to a given item for a specific interval of time to determine one or more of the following:

- I. If the over-voltage can be successfully withstood either for a given length of time, or indefinitely.
- II. If defects in material or workmanship that affect the voltage breakdown are present.

Suitable dielectric tests are commonly applied to the following main groups of electrical products:

- I. Insulating materials: solids, liquids, gasses.
- II. Components: switches, relays, transformers, circuit breakers, potentiometers, cabling, etc.
- III. End products: appliances, motor generators, instruments, office machines, the control equipment of aircraft, machine tools, etc.
- IV. Repaired or rebuilt products: rewound motors, generators, transformers.

Most of the dielectric tests now in use fall into one of the following types:

- I. DESIGN TESTS are primarily a tool of the manufacturer to determine in advance the adequacy of equipment design to meet probable service conditions.
- II. ROUTINE PRODUCTION TESTS are used to detect defects in material or workmanship in processing the equipment through the plant, and in some cases to check equipment design.
- III. ACCEPTANCE TESTS are made by a purchaser to prove that purchased items meet minimum insulation specifications for his own product, and prevent faulty components from being incorporated in the final product.
- IV. SERVICE or MAINTENANCE TESTS are valuable in determining at various periods during the life of the equipment whether or not deterioration has taken place, and to what extent.

HYPOT JUNIORS can be used effectively for all the above types of tests, but have found greatest application in Types II and III.

METHOD OF APPLICATION

Since the basic purpose of the high potential dielectric test is to insure the quality of insulation, it follows that the HYPOT JUNIOR must always be connected so that its output test voltage appears ACROSS the insulation. To apply this principle let us consider some typical methods which would be employed on the main groups of electrical products previously mentioned:

- I. Insulation materials. In general, the test voltage is applied to the test sample by placing the sample

between two metallic electrodes connected to the HYPOT output. For a suggested method of procedure, a valuable reference is ASTM STANDARD D 149.

II. Components. This class of equipment generally consists of one or more conductors insulated from associated metal parts. Voltage would be applied by connecting the high voltage lead to the conductor and the ground lead to the metal parts. If the conductors are tied together and the metal parts also tied together, all the insulation could be stressed with one application of voltage. If conductors and/or metal parts are isolated from each other, several successive applications of voltage may be necessary to properly test all the insulation. For example, in the case of a transformer, three tests would normally be required:

- A. Low voltage winding to frame (ground).
- B. High voltage winding to frame (ground).
- C. Low voltage winding to high voltage winding.

III. End products. These usually represent one or more complete circuits which include a variety of components. Voltage application would be with HV output of the HYPOT connected to circuit conductors and the ground lead to the metal part or parts. Again, if there are circuits or metal parts which are not tied together, several successive applications of voltage may be necessary. On most appliances the HV lead would be connected to one of the conductors at the input plug, and the ground lead connected successively to as many metal parts as necessary to insure completely effective insulation between conductors and all potentially conductive surfaces.

IV. Repaired or rebuilt equipment. The same technique is generally followed as on the new item, except voltage and time of application is reduced.

HYPOT JUNIOR DESIGN FEATURES

The following advanced design features are found in all HYPOT JUNIORS:

- I. High reactance type transformer, designed so that the output voltage will collapse should the current output exceed a given value. The chief advantage of the high reactance transformer is this inherent

current-limiting action which eliminates the need for a circuit breaker and prevents destruction of the item under test. Since current-limiting does not depend on mechanical parts, its action is instantaneous and affords operator protection.

- II. Output kilovoltmeter. The HYPOT JUNIOR kilovoltmeter is a diode rectified meter connected directly across the high voltage output, and has an accuracy of $\pm 3\%$ of full scale.
- III. The "BREAKDOWN" indicator. This is a neon lamp connected across an RF choke in the ground return lead. When sufficient RF energy is available, the voltage drop across this choke fires the lamp. This lamp is designated as the "breakdown" indicator because an arcing failure of the equipment under test is necessary to generate sufficient RF energy to cause the lamp to fire. However, on many insulating structures it is possible to get subdued indication prior to the breakdown point, as the intensity of the corona level provides sufficient energy. Therefore, indication on the "BREAKDOWN LIGHT" indicates arcing and/or intense corona in the equipment under test.
- IV. The "LEAKAGE" light. * This is a useful and frequently misunderstood device consisting of a neon lamp connected across a variable resistor in the ground return lead. When the current flowing in the test circuit exceeds a certain value, the voltage drop across the variable resistor fires the neon leakage indicator. On standard HYPOT JUNIORS the leakage light is factory adjusted to glow with a leakage current of 1 milliampere. The units may be field adjusted to operate within a range of .3 milliampere (300 microamperes) to 5 milliamperes as further described.

When the leakage light lights it indicates that the preset value of current has been exceeded, but this does not necessarily mean that there is defective insulation; since the dielectric circuit under test is usually slightly capacitive, a certain portion of the current in the test circuit is due to the capacitive reactance of the unit under test. This capacitive current contributes toward the total current firing the neon lamp. In circuits having considerable capacitance where the capacitive current may be of considerable magnitude as compared to the normal expected leakage current, it may be desirable to reset the leakage lamp to fire at a higher value as described below.

* See appendix.

OUTPUT VOLTAGE vs. CURRENT

Since the HYPOT JUNIOR uses a high reactance type of transformer the maximum current that can be drawn at any given setting of the voltage control is limited. As the load tries to draw more current the output voltage of the HYPOT decreases automatically. If the voltage control on the HYPOT were set for a given output voltage with no connected load and a (resistive) load were connected, the output voltage would tend to drop.

Figure 1, "Output voltage vs. output current for 10% regulation", shows the maximum current that may be drawn without lowering the output voltage more than 10%.

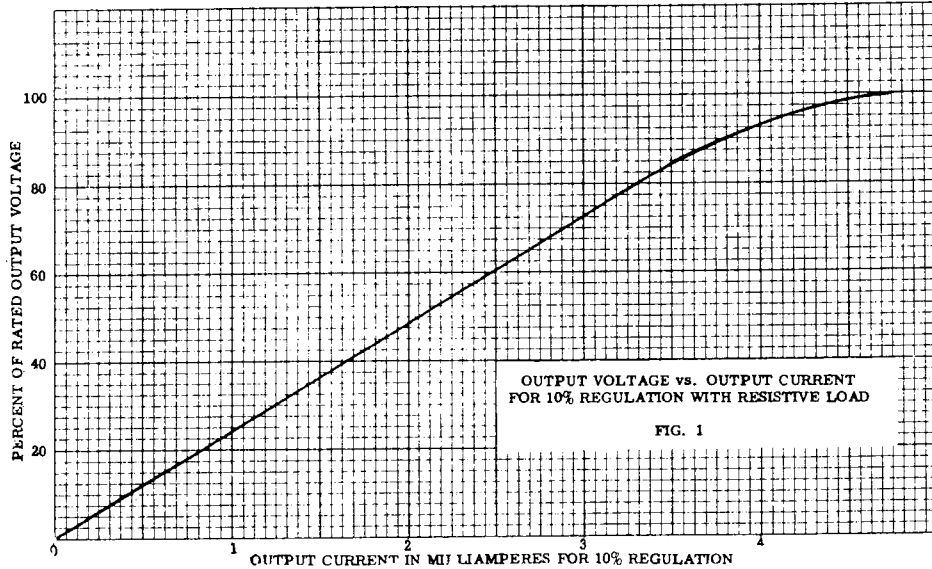

If this load were increased until it actually represented a short circuit across the output terminals, the voltage would drop to zero. Figure 2 indicates the maximum current that could be drawn before the voltage automatically reaches zero.

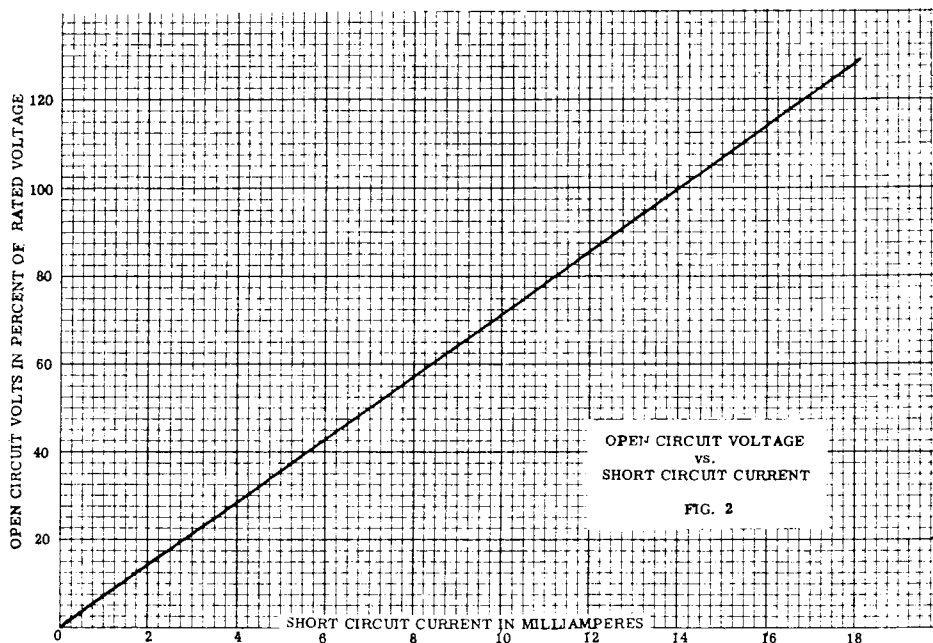

In other words, if the HYPOT were adjusted for full rated voltage (according to the KV meter) a load drawing approximately 5 milliamps could be connected without lowering the voltage more than 10%. If the output were shorted completely, the maximum current drawn through the circuit would be increased to approximately 14 milliamps, and the output voltage would decrease to zero.

It is this inherent automatic current limiting action that prevents damage to equipment under test and helps preserve operator safety. It should be noted that these curves are drawn for resistance type loads. For highly capacitive loads, somewhat higher currents can be drawn. In fact, if the output voltage is applied to a high capacitive load a rise in voltage will be experienced. This is due to a slight resonance effect between the capacitance of the load and the inductance of the HYPOT. Generally speaking, the HYPOT should be connected to the unit under test with the voltage control set at zero and the voltage then raised to the proper value. When this is done the correct voltage will be applied, regardless of the capacitance of the load. If the test voltage must be applied hot, and a bothersome rise in the voltage is experienced, the voltage should be preset to a lower value so that the rise in voltage will reach the required value.

TESTING CAPABILITIES

The actual leakage current of most items varies from a few microamps to several milliamps. When the item under test presents a primarily resistive load, it may be handled without difficulty by almost any of the HYPOT JUNIOR models. Then the question is one of selecting the HYPOT on the basis of the output voltage desired. However, where the physical size of the unit increases, and particularly if motors are present, the distributed capacitance between the conductors and ground increases rapidly so that a point is reached where the current, due to this capacitive reactance, exceeds the output capabilities of the HYPOT JUNIOR. When this condition is reached, the output voltage cannot be built up to the proper value and the leakage light will glow very brightly. In extreme cases of very high capacitance the HYPOT JUNIOR will act exactly as if the output were short circuited, but the inherent current limiting feature of the instrument will prevent any detrimental effect. For example, a large AC motor may draw a charging current as high as several hundred milliamps at a test voltage of 2500 volts, due to the high distributed capacitance of the windings. If a HYPOT JUNIOR were connected between windings and frame of such a motor, no output voltage could be obtained and the leakage light would indicate a short circuit.

The Model 412 HYPOT JUNIOR will deliver its full output voltage with loads having a capacitance as high as 30,000 micro-microfarads. The other models having greater outputs will

of course handle even more capacitive loads. As a rough guide to the typical range of capacitance of manufactured items frequently tested with HYPOT JUNIOR, the following table is supplied.

<u>EQUIPMENT</u>	<u>APPROXIMATE CAPACITANCE IN MICRO-MICROFARADS</u>
Hair clippers 115 volt, 60 cycle, 15 watt	70
Polyphase induction motor, 5 H.P. 350 volt, 60 cycle, 3 phase	2500
Single phase, capacitor starting, induction run motor, 1 H.P., 115/230 volt, 60 cycle	850
Single phase, capacitor starting, induction run motor, 1/6 H.P., 115 volt, 60 cycle	700
Single phase, shaded pole induction motor, 11.5 watts, 115 volt, 60 cycle	100
Universal (series) motor, 115 volt, AC/DC, 2.5 ampere	215
Hand drill, 115 volt AC/DC, 1.3 ampere	285
Bell ringing transformer	100
Toy transformer, 75 watt, 60 cycle	150
Low rate type battery charger, 6 volts, 4 ampere DC output	200
High rate type battery charger 7/14 volts, 100/80 amperes	1000
Soldering gun 115 volts, 60 cycle, 200 watt	175
AC tap type arc welder 100 amp, 25 volt output	400
Radios	50,000
Television sets	50,000
Enclosed switch, 3/4 H.P., 30 ampere, 115/230 volt AC	60
Circuit breaker, 30 ampere, 115/230 volt	10

EQUIPMENT

APPROXIMATE CAPACITANCE
IN MICRO-MICROFARADS

Solenoid coil of magnetic starter, 550 volt, 60 cycle	100
Solenoid coil of valve, 115 volt, 60 cycle, 6 watt	100

It is evident from the above that an extremely wide range of items can readily be tested with HYPOT JUNIORS, even including 5 H.P. induction motors. The only items tested that would probably represent borderline cases would be the radios and television sets.

LEAKAGE LIGHT ADJUSTMENT *

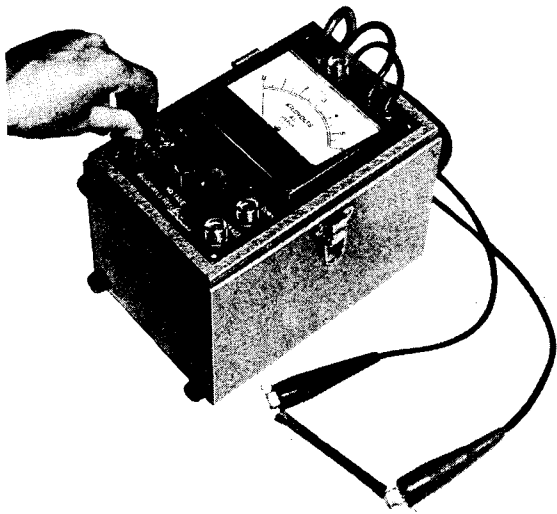

The HYPOT JUNIOR is normally factory adjusted to cause the leakage light to glow when a current of 1 milliamperè is drawn. Because of the wide variety of items that can be tested with the HYPOT, there are many applications where the standard setting would cause needless indication. Ideally, the leakage light should be set high enough so that there is indication only when an abnormally high leakage current flow takes place, thus indicating a real defect. When experience

proves that the factory setting of the HYPOT is too high or too low, the setting may be adjusted as follows:

For tests of material or items with low capacitance, first determine the leakage resistance that will permit the maximum acceptable leakage current. To do this divide the required test voltage (thousands of volts) by the maximum permissible leakage current (in milliamperes). The figure thus arrived at will be the leakage resistance in megohms. A commercially available resistor of approximately this value should be obtained and used as a test standard. In some cases (as described below) where the capacitance of the load is high, the reactance is correspondingly low, and the reactive or capacitive current may be considerably higher than the leakage current. The leakage light (since it is sensitive to both these currents) may therefore glow with good samples of material under test. To correct this condition, it is necessary to measure the capacitance of the specimen by using a capacitance bridge or other standard test methods. A commercially available capacitor close to this value (with a sufficiently high voltage rating) should then be connected in parallel with the test resistance (as determined above).

* See appendix.

Remove the snap plug on the front panel, insert a small screwdriver in the hole and adjust the slotted potentiometer shaft visible within the hole. Turning the shaft clockwise will increase, while turning it counter-clockwise will decrease the current required to light the leakage light. At minimum setting the leakage current will be approximately .3 milliampere (300 microamperes), while at maximum setting it will be approximately 5 milliamperes.

Connect either the standard resistor or the resistor and capacitor combination (referred to above) across the output of the HYPOT and raise the voltage to the previously selected test value. Then adjust the leakage potentiometer until the light glows. Reduce the voltage to zero, reinsert the snap fastener and the unit is ready for operation.

As an alternate method of rough adjustment, several units may be selected and put into two groups: group one consisting of units known to be good, and group two of units known to be borderline or defective. Then adjust the leakage light as indicated above so that the light does not glow when connected to the good units, but does glow when connected to the poor units.

When measurements are to be made on various types of units each having considerably different capacitance, several standards should be made up to assure that the calibration of the HYPOT corresponds to the unit being tested.

THE BREAKDOWN LIGHT

The breakdown light is responsive to a broad band of RF frequencies such as those generated when breakdown or arcing across insulation takes place. Since this light is only sensitive to RF currents it will not normally indicate when the equipment under test is short circuited or when high leakage currents are present, but will indicate any time there is actual sparking, arcing or corona. On the other hand, since arcing is normally associated with relatively high currents, the leakage light will usually indicate simultaneously with the breakdown light. If the output voltage of the HYPOT JUNIOR is raised to a high value and then the connection is made to the equipment under test, the breakdown light will sometimes flicker. This does not necessarily indicate an actual breakdown, but usually is due to the fact that as the hot lead is brought to the equipment there is a point reached where the air gap separating the test lead from the equipment is decreased sufficiently to permit current flow by arcing through the air. Once physical contact is established, the arcing ceases (assuming no breakdown of the equipment). This arcing is therefore normal to the establishing of the circuit, and does not in itself indicate any breakdown in insulation.

AUTOMATIC SQUAWKER HYPOT

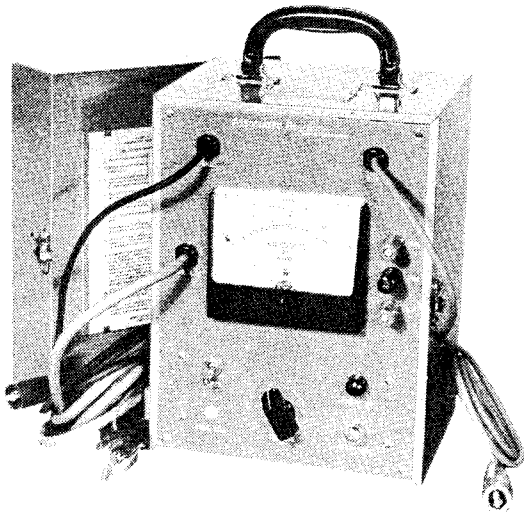

The Automatic Squawker HYPOT was designed for use in performing the same tests as the HYPOT JUNIOR, except an audible signal unit and external control terminals were added, which operate simultaneously with the visual LEAKAGE indicator. This HYPOT is most useful when a predetermined output voltage can be set, leaving the operator free to make various connections with the output leads to the item or items under test, without the necessity of observing the visual indicator for detection of failure.

sity of observing the visual indicator for detection of failure.

DESIGN FEATURES

- I. The AUTOMATIC SQUAWKER HYPOT incorporates the same type high reactance transformer and kilovoltmeter as described above under HYPOT JUNIOR.

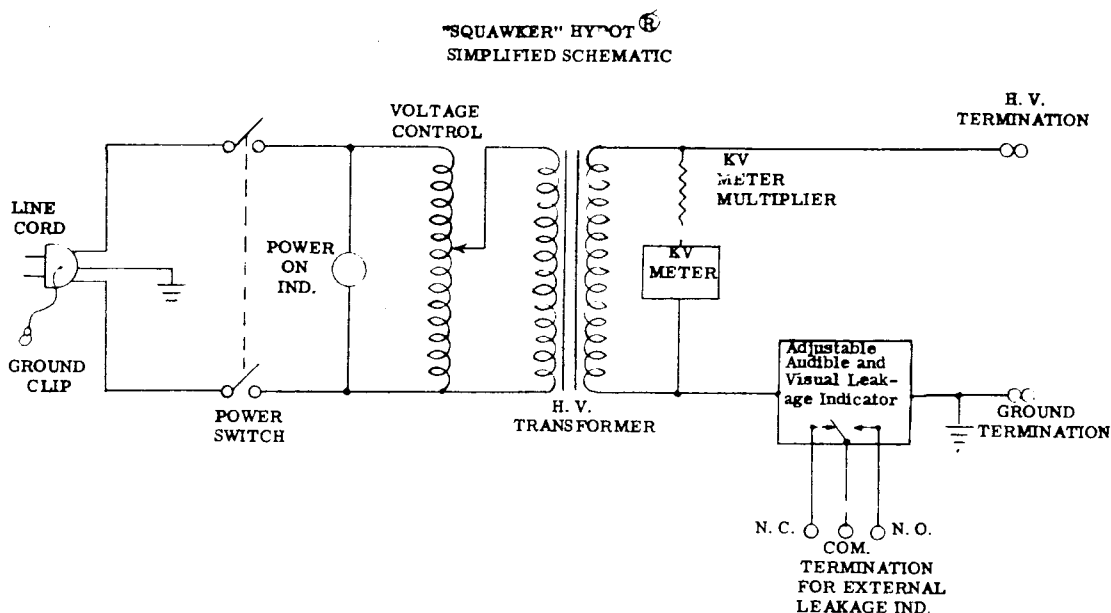

- II. The stock AUTOMATIC SQUAWKER HYPOTS (Models 4003, 4013, 4033 and 4053) incorporate a combined LEAKAGE and BREAKDOWN light. Since the AUDIBLE SIGNAL HYPOT was designed to allow the operator to detect failure by an audible signal rather than observing a failure indicator light, a separate visual indicator for BREAKDOWN and LEAKAGE is usually not required. Therefore, these two indicators were combined into one. However, differentiation between breakdown and leakage may be made by observing the voltmeter if the operat-

or is free to do so. When BREAKDOWN failure occurs, the kilovoltmeter will oscillate, while LEAKAGE failure will have no effect on the kilovoltmeter reading. The leakage current flowing in the test circuit develops a voltage drop across a variable resistor which is connected in series with the GROUND return lead. When the preset leakage current flows through the resistor, an internal relay actuates and completes a circuit to an internal audible as well as the panel visual indicator. These indicators being current sensing devices will also operate when a BREAKDOWN occurs, since normally a high current flows during arcing conditions.

- III. In addition to the internal audible signal and the visual indicator, provisions are made on the panel for connecting to an external alarm or control circuit. This consists of a single pole, double throw relay contact arrangement terminated in three binding posts on the panel. The relay is internal to the instrument and actuates from the same signal as the internal alarm. The external alarm and its power supply can be connected between the COMMON binding post and either the NORMALLY OPEN or NORMALLY CLOSED binding post, depending on the type of external alarm circuit being used.
- IV. The range and method of adjustment of the leakage alarm is the same as for the standard HYPOT JUNIORS.

AC/DC HYPOT JUNIOR

DC HYPOT JUNIOR

The AC/DC and the DC HYPOT JUNIORS are similar in appearance and general design to the AC Hypot Juniors described on the previous pages, but differ somewhat in circuit details and testing capabilities. The following paragraphs point out these differences.

Simplified schematic diagrams of the AC/DC and the DC models are given below. They differ from that of the AC HYPOT JUNIOR primarily in the addition of a rectifier and filter capacitor to provide the DC output voltage. Because of the DC output voltage, these units make use of a DC Kilovoltmeter rather than an AC Kilovoltmeter, which permits metering accuracies of $\pm 2\%$ of full scale (as contrasted to the $\pm 3\%$ of full scale for AC).

AC/DC HYPOT[®] JUNIOR
SIMPLIFIED SCHEMATIC

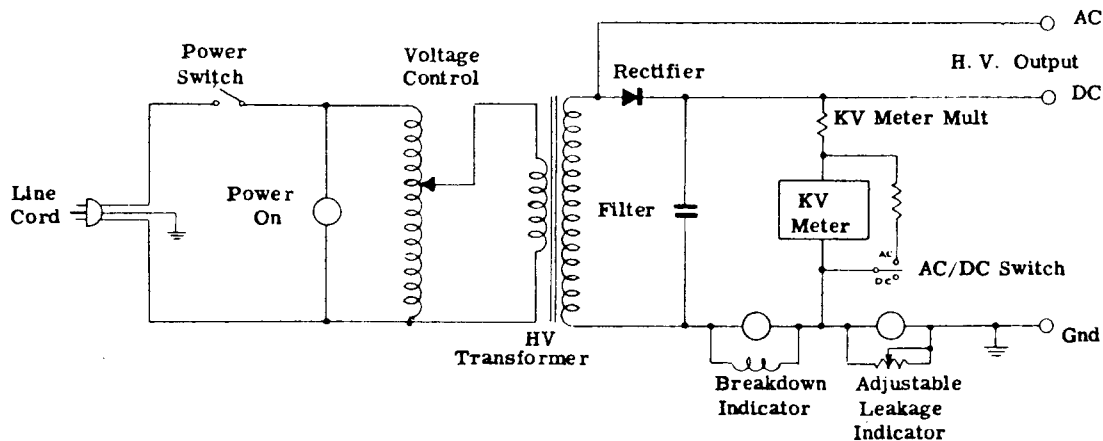

DC HYPOT[®] JUNIOR
SIMPLIFIED SCHEMATIC

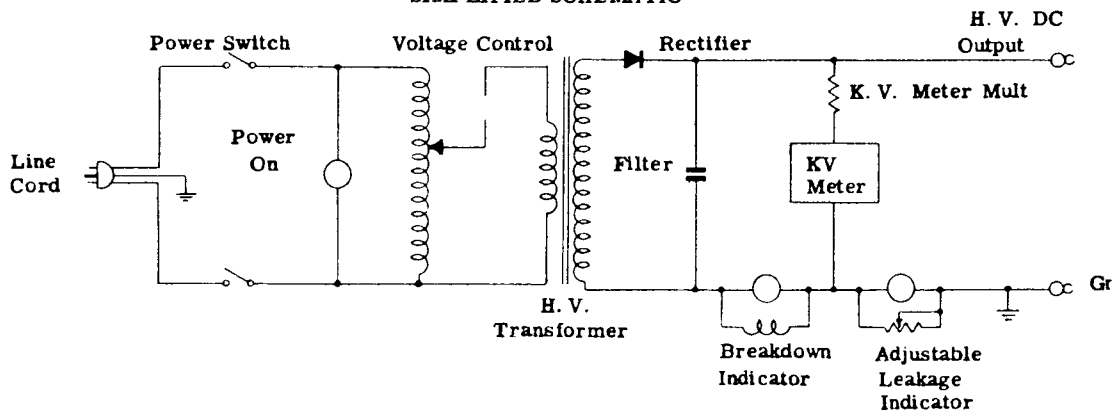

When raising the voltage on the DC HYPOT JUNIOR or on the DC section of the AC/DC HYPOT JUNIOR care should be taken not to turn the powerstat control knob too far. Under lightly loaded or no load conditions full voltage as indicated by the kilovoltmeter will be reached well before the voltage control knob has reached full limit of its travel. Under no condition should the control knob be turned so far that the kilovoltmeter pointer is driven far off scale. When testing with a heavy load the voltage will drop and further control knob adjustment may be made as required.

The capacitance of the item under test has a different effect when testing with DC than when testing with AC. When testing with AC the capacitance current supplied by the test set may be a considerable portion of the output current and may in fact limit the use of the JUNIOR HYPOT as explained in the section on Testing Capabilities. With DC testing the capacitance of the item causes an initially high charging current which gradually decays to the steady state leakage current so that the final output of the test set is virtually the true leakage current. The higher the capacitance and the higher the test voltage the higher the initial charging current will be.

Since the leakage indicator is a current sensing device it will frequently light while the high charging current is flowing. Once the item under test has become fully charged the leakage indicator will extinguish if the insulation leakage is lower than the preset value. When testing a large item this high inrush current may be limited by gradually raising the voltage from zero. If the indicator lights, momentarily stop raising the voltage and wait several seconds. If the light goes out it is definite indication that the original lighting was due to the charging current, and raising the voltage may then be continued. If the light stays on, then the leakage current exceeds the indicator current setting. Because the steady state current supplied on the DC test is primarily leakage current, there is theoretically no limit to the size of the apparatus that may be tested with a DC HYPOT JUNIOR if the actual leakage current is less than a couple of milliamperes.

The capacitance of the item under test merely determines the length of time required to reach full voltage. In general it will take about two seconds per microfarad of load capacitance to reach full voltage. Therefore, the larger the item under test the slower the voltage should be raised. With the voltage control at a given setting, the item under test may be considered to be fully charged when the pointer of the voltmeter stops climbing.

Adjustment of leakage indicator is made in the same manner previously described in the section "Leakage Light Adjustment". With the DC or the DC section of an AC/DC HYPOT JUNIOR, it is unnecessary to connect a capacitance across the load resistor since the test item capacitance has no bearing on the leakage light setting. However, because of this factor, the AC/DC unit may be calibrated for a given value either for AC or for DC. If it is calibrated for one and the AC/DC selector switch position is changed, the calibration may also change.

In general the performance and characteristics of the DC section of the AC/DC HYPOT JUNIOR is the same as the DC HYPOT JUNIOR and the performance and characteristics of the AC section are the same as that of the standard AC HYPOT JUNIOR.

The maximum output current at maximum voltage for the DC HYPOT JUNIOR and the DC section of the AC/DC HYPOT JUNIORS is 2.5 milliamperes. A curve showing the output voltage vs. output current for 10% regulation is given below. This curve shows the maximum current that may be drawn at any voltage setting without lowering the output voltage more than 10%.

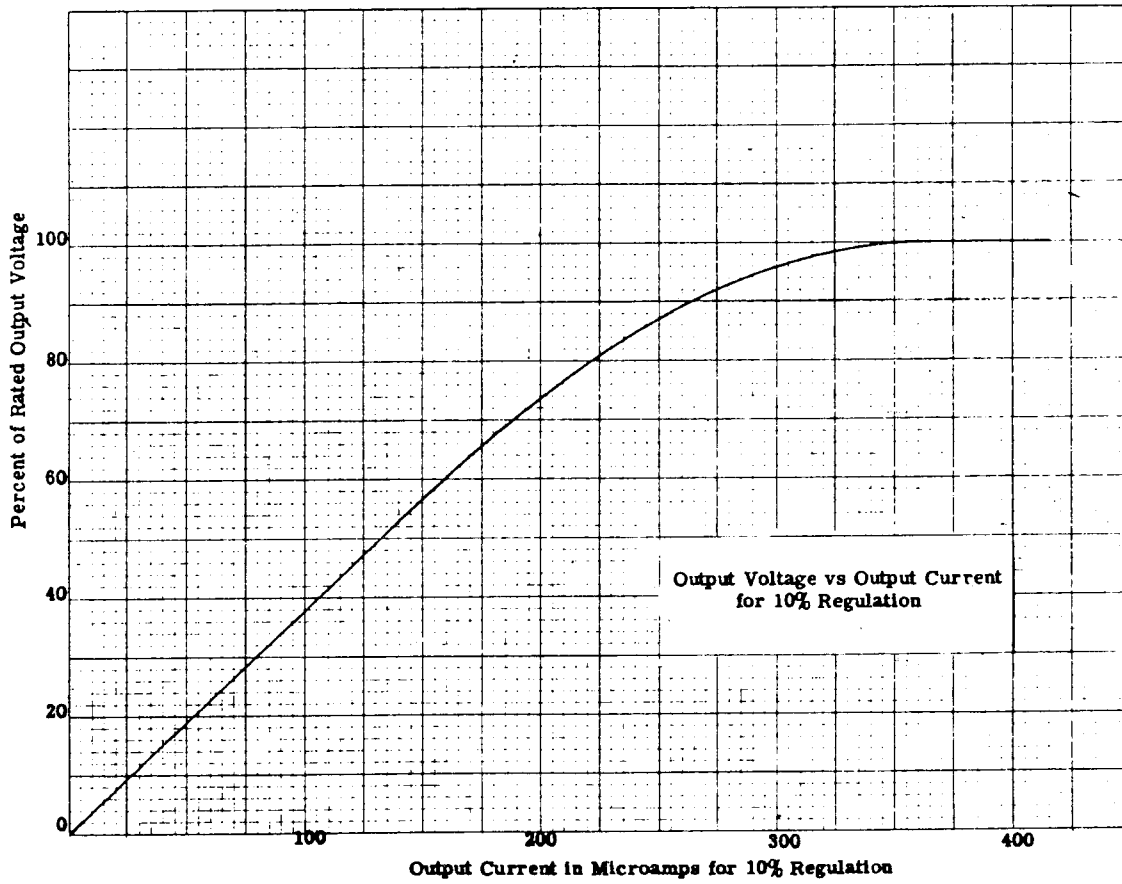

APPENDIX

LEAKAGE RANGE

Prior to February, 1981, the adjustable leakage range for all Hypot Juniors described in this manual (except models 4025 and 4026) was .3 milliampere (300 microamperes) to 3 milliamperes, factory set at .5 milliampere.

If your particular application or technical questions are not answered in this manual, please do not hesitate to write us. Your questions will be given prompt attention by our applications engineers.

If you have an instrument requiring repair or recalibration, we suggest it be returned to our service department for prompt and accurate service. Whenever writing us regarding a particular instrument, please give the model and serial numbers.

"HYPOT"

**A Registered Trademark
of
Associated Research, Inc.**

